

# MAASS™ MODEL MB “QUICK KIT”

*An economical, high quality, pitless unit featuring quick delivery for larger submersible pumps and 8” or 10” wells.*

*Available for municipal, commercial and industrial water well systems.*



NSF 61/372

**MAASS**  
**MIDWEST**

MANUFACTURERS OF QUALITY WATER WELL ACCESSORIES  
© MAASS Midwest Manufacturing, Inc. All rights reserved.  
Specification #200-B

# Introducing: The NEW Model MB "QUICK KIT" Pitless Unit!

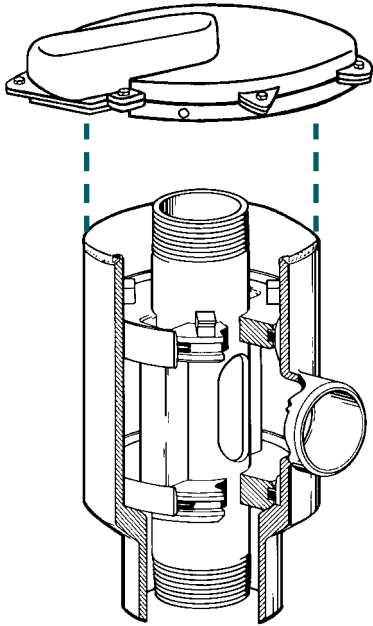

- Easy assembly • only one weld
- For larger submersible pumps
- FDA and NSF approved coating, buff color.
- 304 Stainless Steel o-ring & spool seats
- Made in the U.S.A.
- Convenient • UPS and Air freight shippable
- Meets Great Lake Upper Mississippi River Board of State Sanitary Engineers Standards

Simple and easy to assemble. Only one weld is needed to attach the upper barrel to the housing. Upper barrel can be made for any length bury depth needed. Watertight style aluminum cap is easily bolted to top of the upper barrel.

## The Maass Model MB Quick Kit is comprised of three components:



**1 WATERTIGHT CAP**  
of strong, lightweight cast aluminum, with 2" NPT electrical conduit tapping.



**2 SPOOL**  
with buna-n o-ring seals and NPT threads on spool pipe.



**3 HOUSING**  
with .50 thick wall and 304 Stainless Steel o-ring and spool seats.

Spool and housing coated with FDA and NSF approved catalytic epoxy.

Only the upper barrel, made from standard well casing, has to be added.

The Model MB Quick Kit gives you a quality, competitive pitless unit for your commercial, industrial or municipal submersible pump applications. The MB Quick Kit will save you freight and material cost, giving you the competitive edge. Future well service will be assured with Maass Midwest's use of 304 stainless steel o-ring and spool seats. When spool is pulled there is no restriction of well casing I.D. to impede well service.

Your Model MB Quick Kit can quickly and economically be shipped via UPS or air freight. Your distributor or Maass Midwest can quickly ship two standard size kits; MB for 8" well casing with 4" spool pipe and 4" plain end discharge or 10" well casing with 6" spool pipe and 6" plain end discharge.

MB pitless units are available with "all wetted parts" or 100% Stainless Steel by special order. Maass Midwest can also custom design full pitless units up to 30" well casing to meet your water system needs. Booster Pump Stations and Line Shaft Turbine Pump units are also available. Contact Maass Midwest.

MODEL:	WEIGHT:
MB, HD S - 8, 10, 4, P - 4, NPT - AWT - 0	168 #
MB, HD, S - 10,12, 6, P - 6, NPT - AWT - 0	255 #

MODEL	HOUSING	SPOOL	CAP	OPTIONS
MB				
HD	Heavy Duty			
S	Submersible			
	Casing Diameter = (8" or 10")			
	Upper Barrel Diameter = (10" or 12")			
	Discharge Diameter = (4" or 6")			
	Discharge Type:			
	MT = Male Thread	P = Plain End		
	FT = Female Thread	F = Flanged		
	Pump Pipe = (4" or 6")			
	Thread = NPT			
	Well Cap: AL = Aluminum Cap			
	AWT = Aluminum Watertight Cap			
	Bury depth (if upper casing is ordered)			
	ATB = Airline Test Block			
	TA = Torque Arrestor			

### OPTIONS:

- ATB Airline Test Block
- TA Torque Arrestor\*
- AL Aluminum Sub. Cap
- F Flanged 150# Steel
- MT Male NPT Thread
- FT Female NPT Thread

\* Lift out bail between spool and torque arrestor provided by fabricator.

Patented #4,298,065; 4,416,328; 4,531,664

©2007, MAASS Midwest Manufacturing, Inc.



MANUFACTURERS OF QUALITY WATER WELL ACCESSORIES

U.S. & CANADA 1-800-323-6259 • FAX 1-847-669-3230 www.maassmidwest.com

P. O. Box 547, 11283 Dundee Road, Huntley, IL 60142-0547 • (800) 323-6259 • IL AREA (847) 669-5135

MEMBER:



LISTED PAS-97(04)  
PITLESS ADAPTER STANDARD